

Your Data:

Name: _____

Company: _____

E-Mail: _____

DIMENSION SHEET- OUTER INFLATABLE BELT

Please make your selection and send it to us.

Your choose

Quantity:

 pcs

OuterØ- tube (mm)

height (mm)

Ø Max. blowing (mm)

inquiry order

NK black 40° Shore

NK white FDA 40° Shore

EPDM <math><10^5 \Omega</math> 40° Shore

Silicon nature FDA 60° Shore

Other qualities on request

amount: pcs

amount: pcs

amount: pcs

Outer connectors on request

V2A Span tape 13 mm wide

Rubber-quality



Technical standard quality, wear-resistant, notch resistant



FDA-Quality Food safe



Electrically conductive antistatic



Temperature resistant (+230°C) FDA- Food sector



Valves / Airconnector



Fix connector for 6mm tube

R = 16 mm



1/8 Zoll external thread

R = 21 mm



V2A-tube Ø 6 x 200 mm long

R = 16mm

Span tape

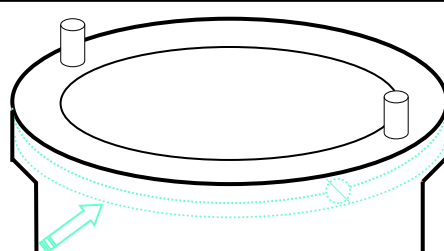

Inflatable belts are in the upper area vulcanized joint to be secured against tearing out by means of a strap.

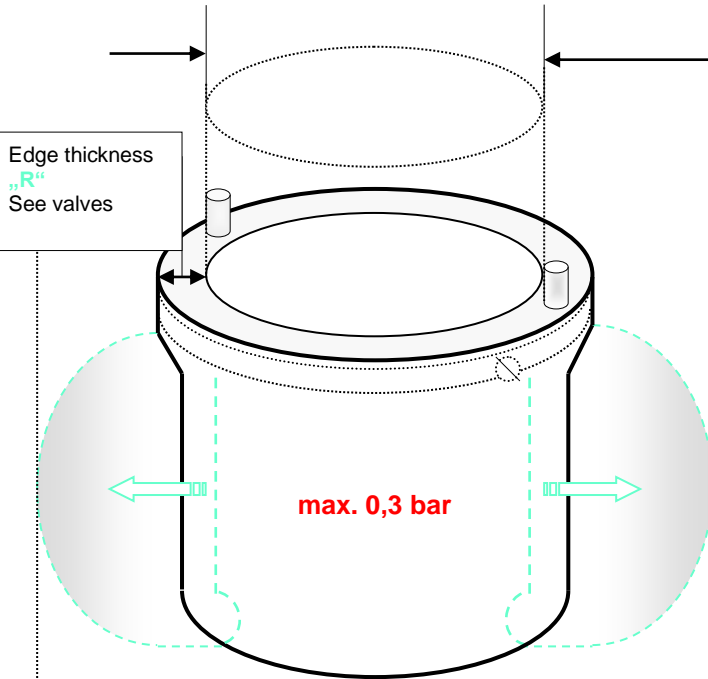

Edge thickness "R" See valves

max. 0,3 bar



Franz-Wachter-Str. 28
70188 Stuttgart
0711 / 48 90 96-3

anfrage@manfred-kunze.de
www.manfred-kunze.de